

**DANIEL  
DATA  
SYSTEMS**

# TOUCH - IT

## Installation & User Manual

Issue 6 / 17-11-94 ( Obsolete stock 2000 )

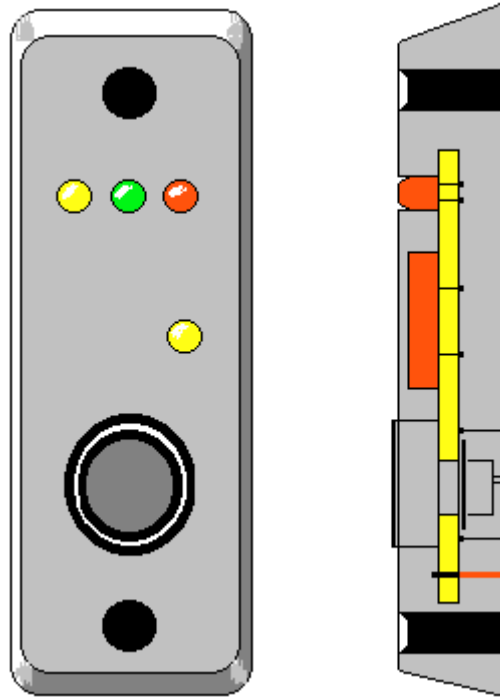

Actual Size

Multilink Access Control Systems Ltd  
71 Hampermill Lane, Oxhey Hall,  
Watford, Hertfordshire.WD19 4NT  
Telephone: 0044 (0)1923 244900  
Facsimile: 0044 (0)1923 224970  
Mobile: 0044 (0)7831 490499  
Email: [info@multilinksecurity.co.uk](mailto:info@multilinksecurity.co.uk)

*TOUCH - IT  
INSTALLATION  
MANUAL*

## **Preface**

---

This manual tells you how to programme the TOUCH - IT system. It deals with the following procedure :

- Installing the controller
- Installing Touch readers
- Wiring equipment to the controller
- Setting the switches on the controller
- Programming the system

**Warning :** To comply with safety requirements, a fail-safe mechanism override must be installed at each card reader exit to allow people to leave the secure area in case of electro - mechanical device failure. This will take the form of either a mechanical handle, knob or break glass unit.

**Caution :** The printed circuit board used in this system is susceptible to damage by static electricity. When handling the equipment ensure your work area is static safeguarded.

### **UK Technical support line:**

Multilink Access Control Systems Ltd  
71 Hampermill Lane, Oxhey Hall,  
Watford, Hertfordshire.WD19 4NT  
Telephone: 0044 (0)1923 244900  
Facsimile: 0044 (0)1923 224970  
Mobile: 0044 (0)7831 490499  
Email: [info@multilinksecurity.co.uk](mailto:info@multilinksecurity.co.uk)

# **Contents**

---

<b>Chapter 1</b>	<b>Overview</b>	<b>5</b>
	Single door system with electric release	6
	Two door system with electric release	7
	Single door system with electro magnetic lock	8
	Two readers controlling a single door with electro magnetic lock	9
	Two door system with electro magnetic lock	10
	Accessories	11
<b>Chapter 2</b>	<b>Installing the controller</b>	<b>12</b>
<b>Chapter 3</b>	<b>Wiring equipment to the controller</b>	
	Readers	
	Touch reader	13
	Ancillary equipment	
	Door contacts - input devices	14
	Request to exit button	14
	Lock devices	15
	Relay outputs	15
<b>Chapter 4</b>	<b>Setting the controller PCB switches</b>	
	PCB switch layout	16
	Door open time	17
	Touch Reader technology, switch settings	17
	One or two door set up	17

## **Chapter 5      USER SECTION** **Programming the system**

General notes	18
New system set up	18
Erasing the memory	18
Reader initialization	18
Entering tokens in the system	19
Adding tokens to the system	19
Erasing tokens	20
Input mode definition	21
User code definition, changing default code 1234	21
Short form programming	22
Definition of technical terms	23
Programming record	24
User register photocopy master	25
Touch Token Schematic	26

# **1. Overview**

---

TOUCH - IT is an intelligent, stand alone, door access system. The single printed circuit board and the power supply unit provide a neat and simple package that is quick and easy to install. A portable infra-red unit is used to programme the system. TOUCH - IT can control up to two readers, on up to two doors if required.

## **Summary of features:**

- ↪ Simple and quick to install and use
- ↪ 300 token capacity
- ↪ Programmed by an infra-red portable programmer.  
(One unit can control infinite number of systems)
- ↪ Any token can be validated or deleted from the system
- ↪ User definable door release time
- ↪ Door forced and door open too long alarm
- ↪ Remote door release (request-to-exit)

## **TOUCH - IT controller with electric release and free turning handle for exit.**

Choose :

- ▭ Number of tokens needed

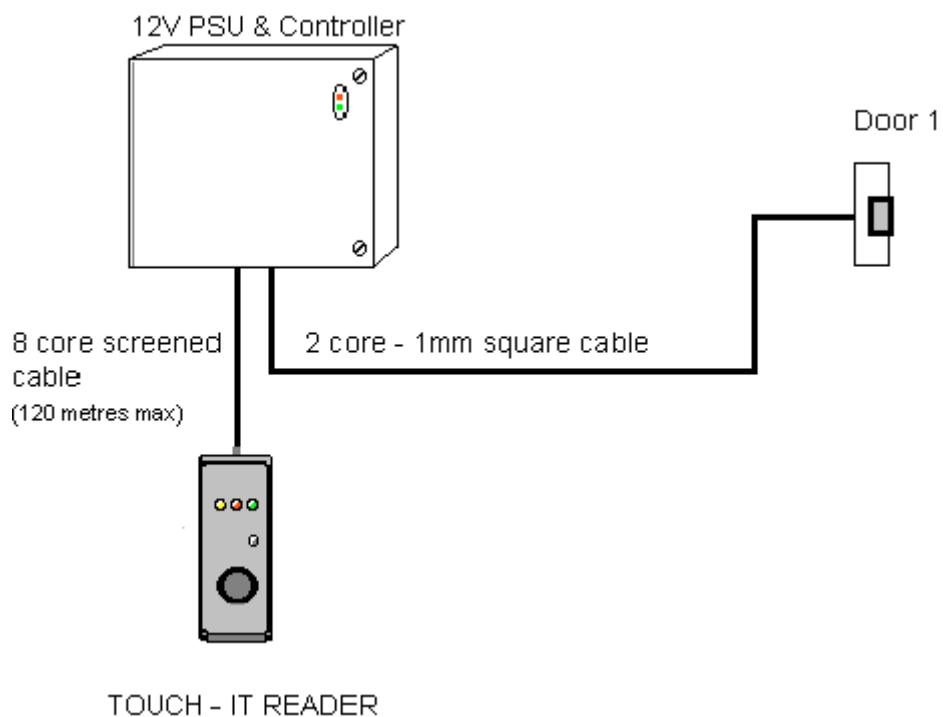

Fig 1.1 Single door system with electric release

## TOUCH - IT controller, controlling two separate doors with electric release and free turning handle for exit.

Choose :

- Number of tokens needed

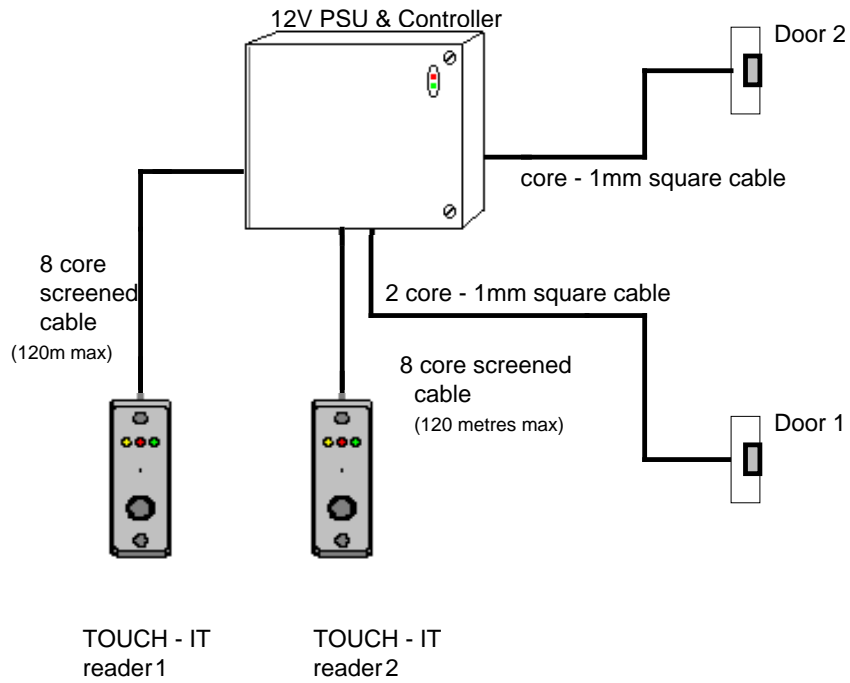

Figure 1.2 Two door system with electric release

## TOUCH - IT controller with request to exit switch, break glass over-ride and electro magnetic lock.

Choose :

- ▢ Number of tokens needed
- ▢ Bracket for lock

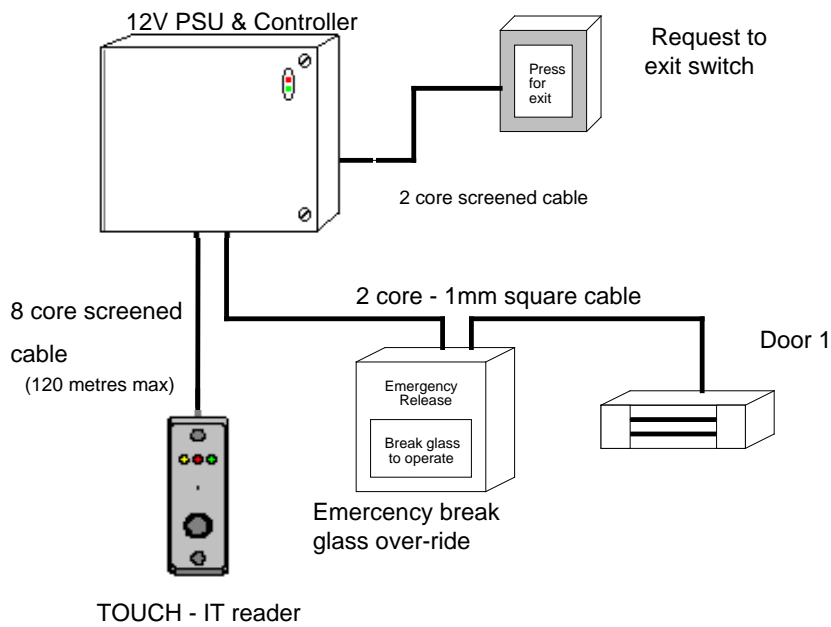

Figure 1.3 Single door system with electro magnetic lock

## **TOUCH - IT controller with two readers controlling one door, break glass over-ride and electro magnetic lock.**

Choose :

- ▭ Number of tokens needed
- ▭ Bracket for lock

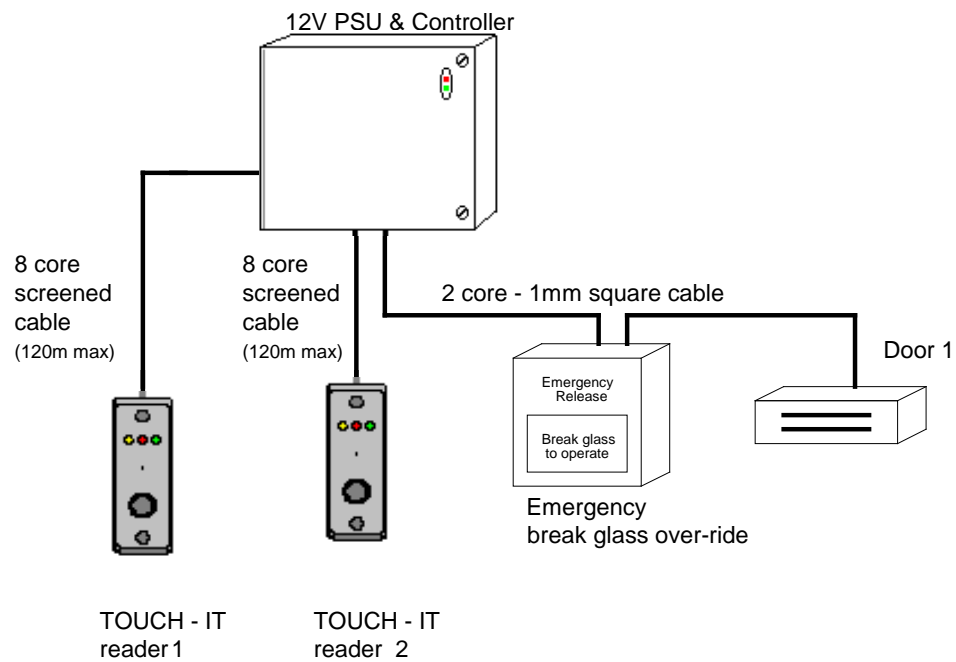

Figure 1.4 Two readers controlling a single door with electro magnetic lock

## TOUCH - IT controller, controlling two separate doors with request to exit switches, break glass over-rides and electro magnetic locks.

Choose :

- Number of tokens needed
- Bracket for lock

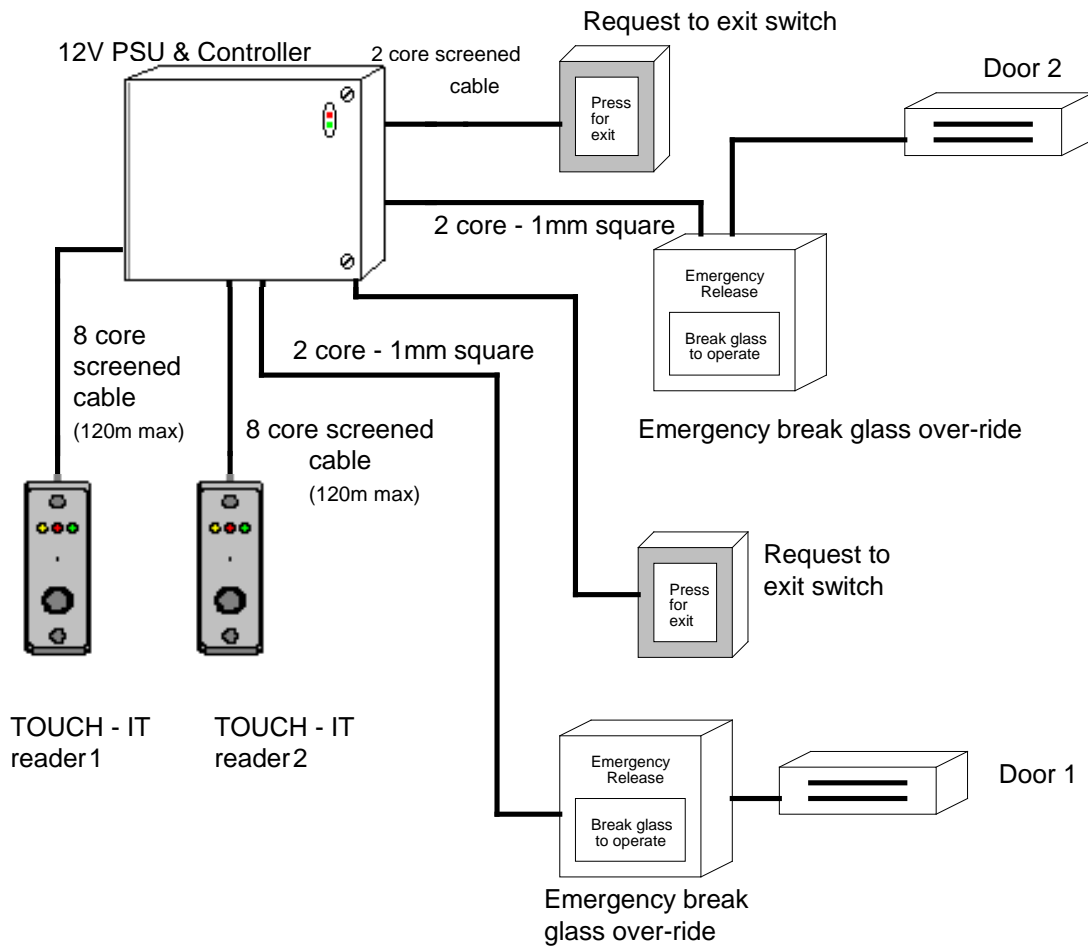

Figure 1.5 Two door system with electro magnetic locks

## **Accessories**

**The TOUCH - IT controller system has the following options available;**

Choose :

- ↪ Type of lock.
  
- ↪ Alarm contact option for touch reader door. A buzzer can be operated to show door forced open and door held open too long. Available on single or two door systems.

## **2. Installing the controller**

### **Important information**

**It is imperative to adhere to the rules below**

1. Fix unit securely to mounting position. The controller should never be mounted or installed in the interior of a high voltage electrical power unit, nor placed in close proximity to large transformers or other high voltage devices. The controller will require regular maintenance, therefore it is important to consider the accessibility of the unit.
2. The controller box must be connected to earth.
3. Connect a clean 240v supply to the mains input terminal. It is important that this line is not being used by other devices serving heavy equipment.
4. To avoid EMI interference it is vital to use the correct cables for wiring the external devices. Where shielded cable is being used the cable shielding should only be connected at one end. Connect the shield to the ground at the controller end only.
5. A minimum separation distance of 50 cm must be left between all data/high voltage cables connected to the controller, Also to other cables operating bells and phone lines. Allow separate cable entry points for all data and power cables coming into the controller box.
6. When making connections to the controller relays it is imperative to adhere to the following rules:

The current drain should not exceed 0.5A. If it does, fit an intermediate relay with a separate power supply feeding the external device.
- 7 Always fit a diode across all DC powered solenoid type locking devices or a 0.1 micro -farad capacitor across an AC powered device. NEVER fit these to corresponding terminals at the controller end, always the release. Suggested diode type: MR - 752 - RS Comps. number 261-823

NB Electro Magnetic type release's do not require diodes or capacitors.

### **3. Wiring equipment to the controller**

#### **Touch technology**

( DL04T - model readers )

Maximum distance to controller : **120** Metres

Type of cable : 8 core **screened** cable 22/24 AWG

Controller eeprom description: TPL

JP 4 setting: SW 6 & 7 set to ' ON' ( to the right)

<b>Card reader wire</b>	<b>Reader no:1 - J1</b>	<b>Reader no.2 - J2</b>
Black (0V )	0V	0V
Red (+5V)	Vcc	Vcc
Blue (data)	CLK1	CLK2
Green	GROUND	GROUND
Brown (Led pass)	Led 1	Led 4
Orange (Led fail)	Led 2	Led 5
White (Led on)	Lon 1	Lon 2
Yellow (buzzer)	Buzz1	Buzz2

**Note that Green connects to GROUND, NOT Dat1, Dat2 or Ov**

Figure 3.1 Wiring configuration for a touch reader

## Door contacts and input devices

A magnetic contact, passive infra-red unit, request to exit switch or any other form of dry contact can be monitored via the TOUCH - IT system. Refer to relay outputs for more information.

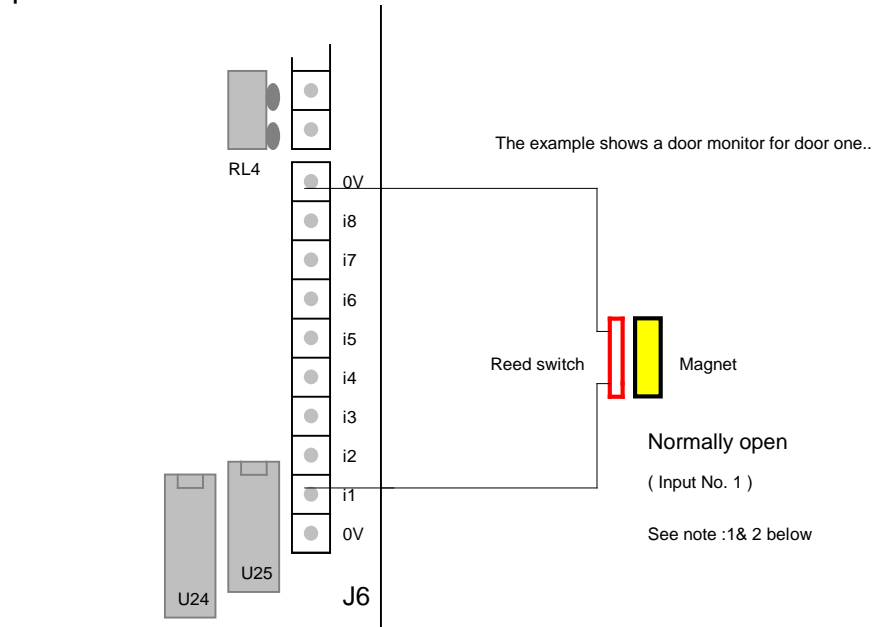

1 door system: Input 1: door alarm (activates relay 3)

Inputs 2, 4, 5, 6, 7, 8: General alarms (all activate relay 4)

2 door system: Inputs 1 & 2, door 1 and door 2 alarms (both activate relay 3)

Inputs 5, 6, 7, 8: General alarm ( activate relay 4)

ALL inputs connect to 0v via each switch, i.e Input 1 to 0v activates relay 3

Fig 3.2 Wiring configuration for Input devices

### Note:

1. Always use screened cable if the distance from the monitor point to the controller exceeds 10 metres or if the installation is in a noisy area
2. The default set-up of the inputs is normally open, any of which can be programmed to be normally closed if required. See page 21 for more details.

## Request to exit button

This button is used to enable the users of the system to open the door for a default time of 4 seconds, from the secure side. Connect a normally open switch as follows:

- 1 door system: Normally open switch between '0v & i3'
- 2 door system: Door 1 as above, door 2 between '0V' & 'i4'

### Note:

1. Always use screened cable between the monitor point and the controller, especially if the installation is in an electrically noisy area.

## Lock device - Relay outputs

The Four relays on the controller can support a maximum of 12V @ 1/2 Amp, do not try to switch more than this as it may damage the controller. See figure 3.3 below, for details of wiring an electronic release. The function of each relay is defined as follows:

**Relay 1:** Door 1 for reader 1 & 2 (SW 3 ' OFF' , JP4)

**Relay 2:** Door 2 for reader 2 (SW 3 ' ON', JP4)

**Relay 3:** Operated if an input on inputs 1 or 2 (two door system) is forced open or the door is held open for more than 10 seconds

**Relay 4:** General alarm relay, operates as follows:

1 door system: general alarm inputs - 2, 4, 5, 6, 7 & 8

2 door system: general alarm inputs - 5, 6, 7 & 8

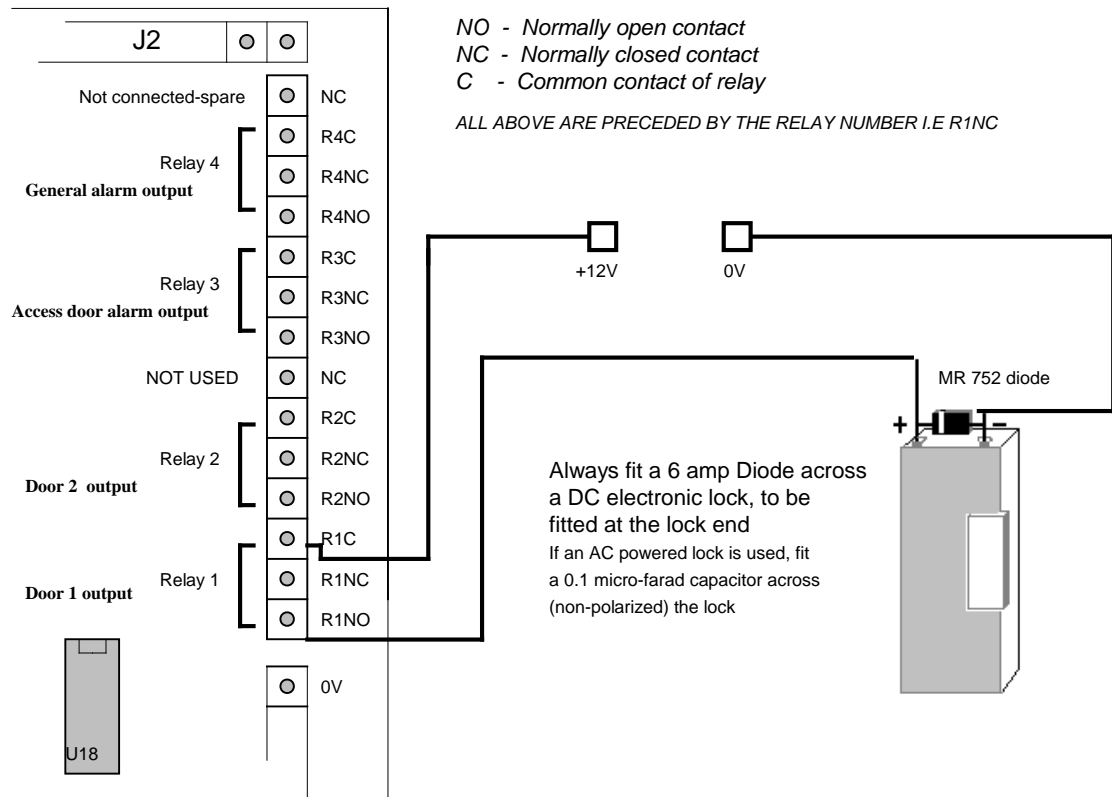

Figure 3.3 Wiring an electronic release

The general alarms can be used for such items as additional door alarms.

## 4. Setting the Controller PCB switches

The diagram in Figure 4.1 shows the switch locations on the controller pcb.

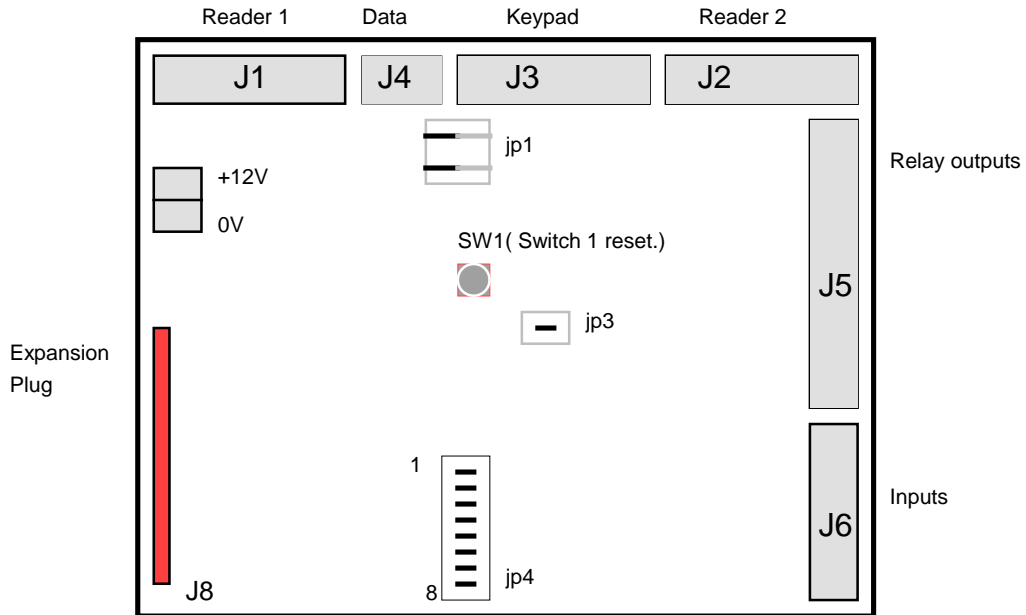

Figure 4.1 Outline of pcb

The switch functions are as follows:

- JP1: Not used
- JP3: Lithium battery on/off - Do not alter
- JP4: Reader technology / number of doors / door open time

## Door open time

The reader door open time is selected with jp4, SW 1 & 2 as follows:

TIME (seconds)	jp4 - switch 1	jp4 - switch 2
1	ON	OFF
2	OFF	ON
4	OFF	OFF
8	ON	ON

Note:

1. The request to exit buttons are defaulted to 4 seconds regardless of the above settings

## Touch Reader technology, jp4 settings

jp4 - switch 6	jp4 - switch 7	jp4 - switch 8
ON	ON	OFF

## Touch system, Settings for 1 or 2 door system

ONE DOOR SYSTEM	TWO DOOR SYSTEM
jp4 - switch 3	jp4 - switch 3
OFF	ON

Please note: JP4 switch 4 must always be set to "off"

## USER SECTION

### 5. Programming the system

#### General notes

In order to carry out system programming an infra-red programmer is needed. Please ensure a battery (type PP9) is fitted into the programmer. Each DL04T reader has an integral infra red cell. To programme the system the infra red programmer must be pointing at reader 1 infra red cell and must be within 0.5 metres and directly in front of the reader.

Please note the location of the ENT key and the F3 key. Be careful to avoid using the F3 key when required to actually press ENT. If this should happen the system enters programme mode, pressing CLR and then the 4 digit user code or press the ENT key to exit the "waiting user code sequence"

#### New system set-up

To set up a new system follow the instructions below.

#### Erase all memory

1. Press the "F3" key on the portable programmer, the green led starts to blink on the reader. Enter the user codes (when the system is new this code is '1234'), press the "ENTER" key. The green and red led will go on for one second, then the green led will blink fast to show that the system is waiting for a command.
2. Enter the code '00' followed by the "ENTER" key, the red and green led's will flash simultaneously to show that the command has to be confirmed. Press the "ENTER" key to confirm the command.

All the system memory has now been erased.

#### Reader initialisation

In order for the system to know how many door are connected we have to follow the following procedure, we should only do this once when the system is new, **please ensure that the switches are set-up with the system powered down standby batteries disconnected.**

*One door system : Switch 3 on jp4 set to 'OFF'.*

*Two door system: Switch 3 on jp4 set to 'ON'*

1. If you are already in the programming mode (green led blinking) go to step two. If not press the "F3" key on the portable programmer, the green led starts to blink on the reader. Enter the user codes (when the system is new this codes is '1234'), press the "ENTER" key. The green and red led will go on for one second, then the green led will blink fast to show that the system is waiting for a command.

2. Enter the code '02' followed by pressing the "ENTER" key, the red and green led's will flash simultaneously to show that the command has to be confirmed. Press the "ENTER" key to confirm the command.

## Entering TOUCH tokens in the system

### Adding tokens to the system

#### Note:

1. If the system is a two door system the token will be valid in both readers.

We have to record each token in the system by recording a number to it from 1 to 300. The procedure is as follows:

1. Decide what the token number will be - usually we use the 3 digits printed on the token.
2. If you are already in the programming mode (green led blinking) go to step three. If not press the "F3" key on the portable programmer, the green led starts to blink on the reader. Enter the user codes (when the system is new this code is '1234'), press the "ENTER" key. The green and red led will go on for one second, then the green led will blink fast to show that the system is waiting for a command.
3. Enter the code '09' followed by the token number, press the "ENTER" key, the green led will flash slowly.
4. Touch the token to be programmed on the reader until the green led goes on for one second.

#### Notes:

1. We can continue to enter additional tokens into the system with the led blinking slowly, Each additional token **programmed** number will be incremented by one. On completion of this procedure the led will continue to flash slowly for a further 30 seconds and then will go out.

***To exit the programme mode press the 'F3' key once.***

Example: To record token number 001, type in 09 001 [ENT] and touch the token on the reader.

2. When a new token is recorded in the system, a token previously recorded under the same number is erased.
3. If a token is already recorded the red and green led's will light for 3 seconds, exit the 09 command and return to the programme mode (green led flashing).

## Erase a token

In order to prevent a token being used in the system, carry out the following procedures:

1. Take note of the token number .
2. If you are already in the programming mode (green led blinking) go to step three. If not press the "F3" key on the portable programmer, the green led starts to blink on the reader. Enter the user codes (when the system is new this codes is '1234'), press the "ENTER" key. The green and red led will go on for one second, then the green led will blink fast to show that the system is waiting for a command.
3. Enter the code '09' followed by the token number, followed by 'F2'.

Example: To erase token number 001, type in 09 001 [F2]

## Input mode definition

Any number of the 8 inputs can be configured as normally open or normally closed according to input device used. The default state is normally open, to change it to work on a normally closed device programme as follows:

1. Press the "F3" key on the portable programmer, the green led starts to blink on the reader. Enter the user codes (when the system is new this codes is '1234'), press the "ENTER" key. The green and red led will go on for one second, then the green led will blink fast to show that the system is waiting for a command.
2. Enter '43 AA N', press the "ENTER" key.

Where: AA = Input number (01 to 08)  
N = 0 or 1 ( 0 = Normally open, 1 = Normally closed)

### USER CODE DEFINITION, CHANGING DEFAULT CODE 1234.

1. If the system is not already in programme mode press F3 followed by user code then go to step 2
2. Type 10 followed by the new user code followed by ENT.

*Example.* To change default or current user code to new code, in programme mode type 10 followed by new 4 digit user code i.e., 10nnnn.

Where: nnnn = new 4 digit user code.

## **Short form programming**

New system only:  
-----

1. Ensure that the links are set-up as follows :

*One door system : Switch 3 on jp4 set to 'OFF'.*

*Two door system: Switch 3 on jp4 set to 'ON'.*

*Touch technology: Switch 6 & 7 on jp4 set to "ON".*

2. Enter programme mode:(all of the steps below have to be carried out in the programme mode, connect mains supply & battery at this point)

<b><u>PROGRAMME MODE</u></b>	<b><u>RESPONSE FROM READER</u></b>
------------------------------	------------------------------------

Press "F3" on hand unit

*GREEN LED BLINKS  
on Touch reader*

Type "password code"  
(default '1234') Press "ENT"

*GREEN/RED LED FLASH ONCE,  
GREEN LED BLINKS*

3. Erase system memory:

Type '00' press "ENT"

*GREEN/RED LED BLINKS*

Press "ENT" to confirm command

*GREEN LED BLINKS*

4. Reader set-up:

Type '02' press "ENT"

*GREEN/RED LED BLINKS*

Press "ENT" to confirm command

*GREEN LED BLINKS*

## 5. Enter tokens:

Type '09' 'token number  
(3 digit)' press "ENT"

*GREEN LED BLINKS SLOWLY*

Touch token on reader

*GREEN LED LIGHTS FOR 1  
SECOND*

Continue to show tokens, they will be incremented in number order, i.e. 001, 002, 003 etc. Any token already recorded and Touched on the reader will be rejected and the system will return to programme mode. The green and red led's will light for 3 seconds before the system returns to programme mode. If this occurs re-enter command 09 and start at next new user number.

Example: Token number 123 is already recorded, system will return to programme mode. With green led blinking (in programme mode) enter 09 124 (next user number) and touch token 124 on reader. Continue touching tokens in sequence,

## 6. Exit programme mode:

Press "F3" once

*GREEN LED GOES OUT*

If command 09 is active (green led blinks slowly) pressing CLR will exit to programme mode. F3 will then exit programme mode.

## DEFINITION OF TECHNICAL TERMS

LED	Light <b>E</b> mitting <b>D</b> iode, a type of electronic lamp the colour of which may vary.
F2 / F3	Function keys which allow or wait for access to a command or confirms a command or action.
Touch Token device	A sealed electronically encoded coin sized containing a uniquely pre-encoded micro chip.
IR	Infra red, in relation to the Touch System, the IR Portable programmer is similar to those used as domestic television channel changing units.

<b>ENGINEERS PROGRAMMING RECORD</b>
<b>SYSTEM INSTALLED DATE</b>
<b>System Number (If multi door system)</b>

	Reader 1	Reader 2
Controller Location ?		
Door location ?		
Two door system ?		
Request to exit button fitted		
Cable length approx.		
Door open time ?		



# Touch Token Schematic

